



Mini Monster®



Overview

For low flow, buildings and small pump station applications the Mini Monster is a reliable grinder in a small package. It grinds wastewater to eliminate costly pump problems and sewer back-ups.



Easy to remove cutter cartridge



In-line Mini Monster



Mini Monster installed in a pump station



In-line Mini Monster

Features & Benefits

Dual Shafted Grinder

- Capable of grinding a wider variety of solids than single shafted machines or macerators
- High torque allows the grinder to handle rags, sticks, clothing, plastics, bedding and more without jamming

Ease and Flexibility of Installation

- Adapts to existing pipeline or channel applications with little or no modification to piping or channel
- In-line unit incorporates a quick-change cutter cartridge

Cartridge Seal Assembly

- High pressure capability – 6 bar
- No seal flush required and no packing gland to adjust

High-Flow Side Rails

- Increases flow rate and decreases head loss
- Deflects solids into the cutting chamber

Compact, Efficient Design

- Cutter and reducer design allows the use of small, energy efficient motors – 0.75 to 1.5kW
- Compact units fit in small spaces

Automated PLC Monitoring and Controls

- Auto load sensing and reversing reduces motor trips, protects system and eliminates need for manual check-ups

*All units Atex certified Grp11 cat 2



www.jwci.co.uk

Mini Monster

Model 20000

Motor: Standard 1.5 ; 0.75kW optional
 Flow rate: In-line: 60 m³/h
 Open Channel: 18 m³/h
 Pressure: 6 bar (working)
 Weight: In-line: 125 kg
 Open Channel: 102kg
 Cutter size: 120mm diameter



In-Line Configuration

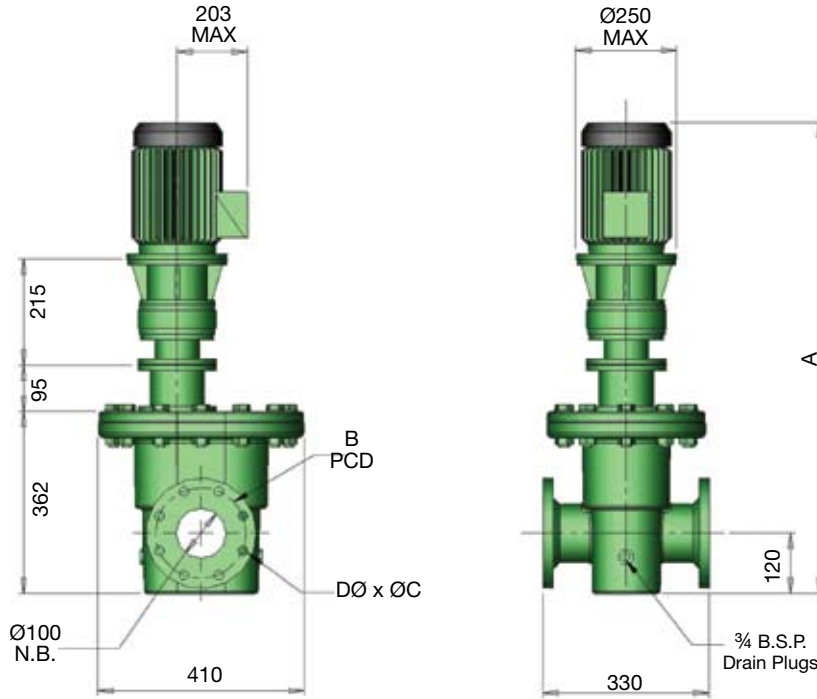

Open Channel Configuration

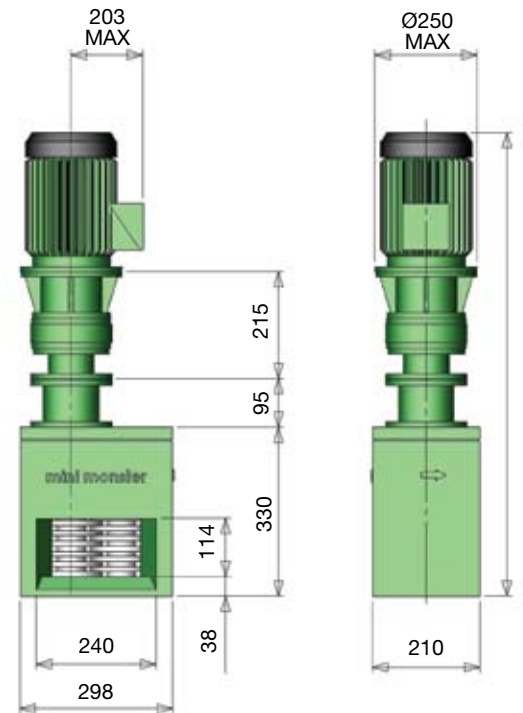

Performance Capability – Open Channel Configuration

Model	Flow Rate m ³ /h	Head Drop mm	Net Weight Approx. kg	Maximum Dimensions - mm	
				A (IP55)	A (IP68)
20002-DI	18	80	102	912	1215

Flow based on optimum channel conditions • Consult factory for final analysis of application • Drive dimensions are a maximum based on a unit with a 1.5 kW drive • Extended drive shafts are available on request.

Performance Capability – In-Line Configuration

Model	Flow Rate m ³ /hr	Pipeline Size-mm	Pressure Drop (Bar)	Net Wt. kg	Maximum Dimensions - mm		Flange Dimensions - BS EN 1092		
					A (IP55)	A (IP68)	B	C	D
20000-D100	60	100	0.07	125	944	1236	180	19 (M16)	8

In-Line unit typically installed prior to suction side of pump • Consult factory for analysis of application • Drive dimensions are a maximum based on a unit with a 1.5 kW drive.



Johannesburg
 Tel: +27 11 397 3536
 Fax: +27 11 397 3512
 info@pumptron.co.za

Durban
 Tel: +27 31 579 1430
 Fax: +27 31 579 4085
 taylor@pumptron.co.za

Cape Town
 Tel: +27 21 552 6036
 Fax: +27 21 552 5865
 deon@pumptron.co.za

Eastern Cape
 Tel: +27 28 572 1722
 Mobile: +27 82 455 3244
 fags@mweb.co.za



Unit 15, Daneside Business Park
 River Dane Road
 Congleton, Cheshire CW12 1UN
 United Kingdom
 Phone: +44 1260 277047
 Fax: +44 1260 277557
 jwci@jwce.com



www.jwci.co.uk